

PMS

Non-corroding cooling towers

**PMS series
PMD
PMC**



PMS - PMD - PMC Non-corroding cooling towers



■ PMS, PMD, PMC series cooling towers

The PMS, PMD and PMC cooling towers are built entirely in fibreglass (orthophthalic polyester resin, reinforced with several layers of glass fibre matting) in order to avoid the problems linked to corrosion frequently encountered with this type of product, since the tower is constantly in contact with water and exposed to the elements. The structure is self-supporting and strengthened at the points of greatest dynamic and static stress. Moreover, the surface of the fibreglass is protected by a gelcoat that is resistant to UV rays, hot and cold water and abrasion due to weathering and chemical agents. The fill pack material inside is made from self-extinguishing PVC with 20 mm wide flute, especially suited to industrial applications. The multi-blade axial fan offers high performance with low electrical power input and the individual aluminum or fibreglass blades are easy to replace whenever necessary.

With 35 different versions, all available with or without a water collection basin, this series covers a range of cooling capacity of 15.000 to 1.625.000 kcal/h, with water flow rates of between 3 m³/h and 325 m³/h with a water temperature range of 5 °C.

■ Special versions

A special "Container" version, designed and built to optimize available space and reduce transport costs, is available for all PMS models. In fact, the tower main casing fits perfectly into the cold water collection basin and, on having reached its final destination, the cooling tower is easily and quickly reassembled with L-profile channels.

The following special versions are also available for the PMS, PMD and PMC series:

- **ATT** - for high temperature inlet water, with max peak temperature of 80°C
- **N** - for water containing modest quantities of suspended solids
- **N-ATT** - for water containing modest quantities of suspended solids and having high inlet temperatures, with max peak temperature of 80 °C
- **GS** - for water containing large quantities of suspended solids

■ Accessories and construction variants

The following accessories and/or construction variants are available for all models on request:

- inspection window (fitted as standard in the PMC series)
- non-clogging spray nozzles
- three-phase heater element with control thermostat
- minimum level cut-out switch
- two-speed motor with graduated thermostat, automatic cascade control panel, or control system with inverter
- sound-attenuated version

Construction details



1 Main casing, basin (optional) and top cap

Construction Materials:

- orthophthalic polyester resin, reinforced with several layers of glass fibre matting

Characteristics:

- self-supporting structure reinforced at points subject to greatest static and dynamic loads
- external surface protection via gelcoat resistant to UV rays, cold and hot water, abrasion due to weathering and chemical agents
- internal waterproofing with an impermeable, water repellent, paraffin-containing orthophthalic gelcoat (for basin)
- light-weight
- non-corroding

2 Fill pack material (or heat exchange surface)

Construction Materials:

- Self-extinguishing PVC

Characteristics:

- 20 mm wide flute (air/water passage), especially suitable for industrial applications
- reinforced top surface to better absorb dynamic stress created by the water sprayed under pressure by the nozzles

3 Multi-blade axial fan

Construction Materials:

- hot-galvanized steel (support), electric motor, aluminium or fibreglass (fan blades), stainless steel (fan safety guard)

Characteristics:

- high performance, low electrical power input
- directly driven by the electric motor
- constant safety, unaltered over time thanks to the protective fan guard
- blades easy to replace should one break

4 Visual inspection window

Construction Materials:

- Nylon body, polycarbonate transparent window

5 Hot water distribution system

Construction Materials:

- PN 10 unified PVC pipes, polypropylene nozzles

Characteristics:

- non-corroding
- uniform and total spraying of the heat exchange - fill pack
- exclusive nozzle design, with large passages to guarantee non-clogging and a full cone spray

6 Hydrometer/bleed-off tap assembly

Construction Materials:

- PVC and AISI 304

Characteristics:

- hydrometer in glycerine bath with AISI 304 casing
- in the absence of a flow rate meter, this device offers immediate control and a good approximation of the flowrate of the circulating water, on the basis of the flow resistance offered by the nozzles (equal to the pressure indicated on the hydrometer)
- plastic bleed-off tap to control water hardness

7 Protective safety-grille

Construction Materials:

- AISI 304/316

Characteristics:

- non-corroding
- unaltered, long-lasting protection/safety properties

8 Bolts, nuts and washers

Construction Materials:

- AISI 304 (no self-tappers used)

Characteristics:

- non-corroding
- easy to dismantle, even after many years of use



TECHNICAL DATA

PMS series model with water basin

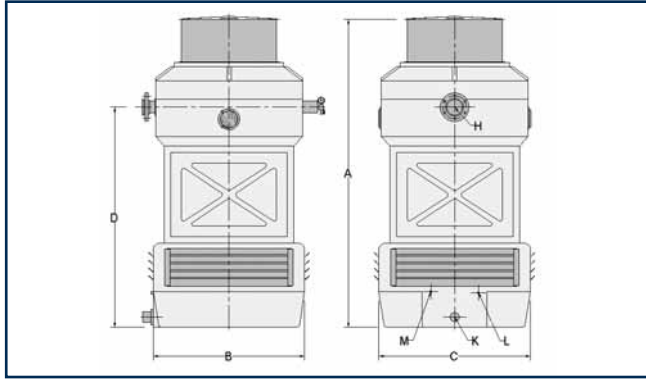

| Model | A mm | B mm | C mm | D mm | H ø | K ø | L ø | M ø |
|-------|------|------|------|------|------|------|------|------|
| 65 | 2110 | 800 | 800 | 1510 | 2" | 2" | ¾" | ½" |
| 85 | 2595 | 1000 | 1000 | 1940 | 2 ½" | 2 ½" | ¾" | ½" |
| 110 | 2800 | 1200 | 1200 | 2050 | 3" | 3" | 1" | ¾" |
| 130 | 2860 | 1400 | 1400 | 2040 | 4" | 4" | 1" | ¾" |
| 180 | 3140 | 1740 | 1740 | 2285 | 4" | 4" | 1 ¼" | 1" |
| 240 | 3380 | 2100 | 1900 | 2400 | 4" | 5" | 1 ¼" | 1" |
| 260 | 3450 | 2300 | 2100 | 2400 | 5" | 6" | 1 ½" | 1 ½" |

PMS series model without water basin

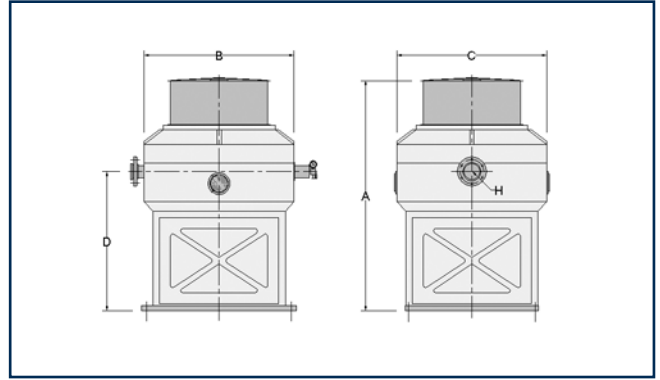

| Model | A mm | B mm | C mm | D mm | H ø | K ø | L ø | M ø |
|-------|------|------|------|------|------|-----|-----|-----|
| 65 | 1560 | 770 | 770 | 960 | 2" | | | |
| 85 | 1895 | 980 | 980 | 1240 | 2 ½" | | | |
| 110 | 2140 | 1214 | 1214 | 1395 | 3" | | | |
| 130 | 2080 | 1360 | 1360 | 1260 | 4" | | | |
| 180 | 2275 | 1710 | 1710 | 1425 | 4" | | | |
| 240 | 2330 | 2005 | 1810 | 1355 | 4" | | | |
| 260 | 2400 | 2210 | 2010 | 1355 | 5" | | | |

PMD series model with water basin

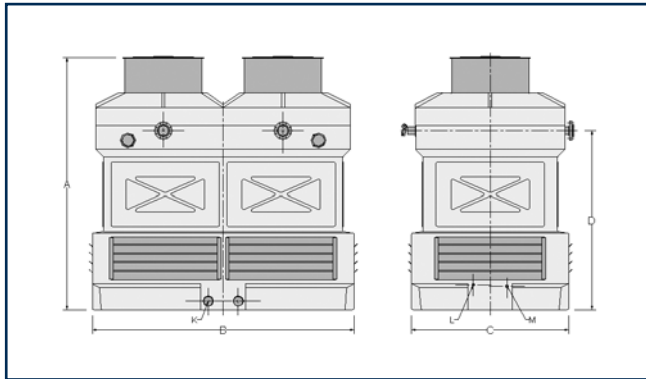

| Model | A mm | B mm | C mm | D mm | H ø | K ø | L ø | M ø |
|-------|------|------|------|------|------|------|------|-----|
| 280 | 3390 | 2710 | 2110 | 2400 | 2x4" | 2x4" | 1 ¼" | 1" |
| 360 | 3380 | 3500 | 2100 | 2400 | 2x4" | 2x5" | 1 ¼" | 1" |

PMD series model without water basin

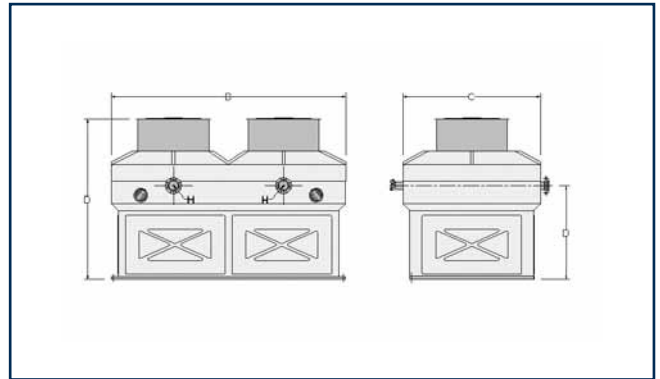

| Model | A mm | B mm | C mm | D mm | H ø | K ø | L ø | M ø |
|-------|------|------|------|------|------|-----|-----|-----|
| 280 | 2340 | 2710 | 2110 | 1355 | 2x4" | | | |
| 360 | 2330 | 3410 | 2010 | 1360 | 2x4" | | | |

PMC series model with water basin

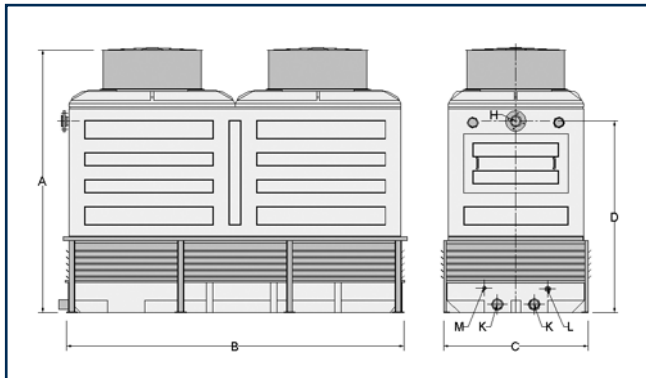

| Model | A mm | B mm | C mm | D mm | H ø | K ø | L ø | M ø |
|-------|------|------|------|------|------|------|------|------|
| 520 | 3790 | 4310 | 2040 | 2610 | 2x5" | 2x6" | 1 ½" | 1 ½" |
| 640 | 4415 | 4010 | 2355 | 3110 | 6" | 2x6" | 1 ½" | 2" |
| 800 | 4260 | 5490 | 2350 | 3105 | 6" | 2x6" | 2" | 2" |

PMC series model without water basin

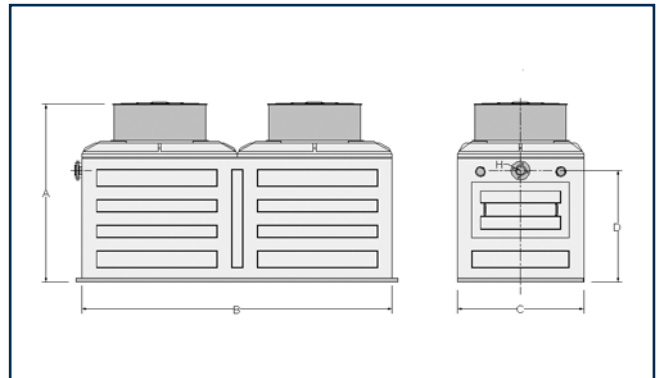

| Model | A mm | B mm | C mm | D mm | H ø | K ø | L ø | M ø |
|-------|------|------|------|------|------|-----|-----|-----|
| 520 | 2620 | 4210 | 1910 | 1440 | 2x5" | | | |
| 640 | 3245 | 3900 | 2300 | 1940 | 6" | | | |
| 800 | 3100 | 5400 | 2200 | 1940 | 6" | | | |

These technical data are subject to variation and without engagement by the manufacturer, please contact Mita's technical depart-

ment to obtain the most up-to-date data.

